



**Global Consulting Inc.**

"Managing projects to success"

## 3-PC SOCKET WELD BALL VALVE



**Global Consulting Inc.**  
"Managing Projects to Success"



### **KSPM-32 (S)**

#### *3-pc Socket Weld Ball Valve*

- Investment casting for body and cap
- Full bore
- Pressure rating 1000 PSI (PN63)
- Working temperature -25°C + 180°C
- Material CF8M, CF8, CF3M, WCB

#### DIMENSION LIST

SIZE	d	D	L	H	W	P	N • m	Kgs
1/4"	11	14.1	43	51	105	10	4	0.34
3/8"	12.5	17.1	43	51	105	10	4	0.33
1/2"	15	21.7	54	53	118	10	5	0.35
3/4"	20	27.1	73	60	118	14	8	0.75
1"	25	33.8	79	75	150	14	10	1.11
1 1/4"	35	42.5	90	80	150	15	14	1.61
1 1/2"	40	48.6	102	88	182	15	18	2.55
2"	50	61.1	118	95	182	19	25	3.32
2-1/2"	65	73.8	152	121	254	21	48	6.40
3"	80	89.8	180	135	254	24	75	10.85
4"	100	115.2	218	158	285	24	110	19.05

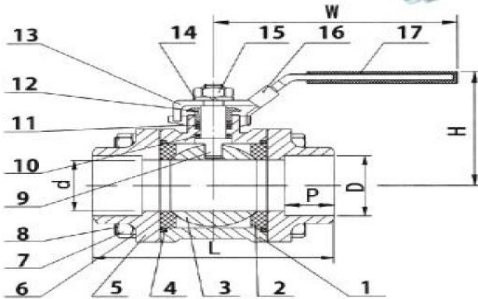

### **KSPM-32 (B)**

#### *3-pc Butt-Weld Ball Valve*

- Investment casting for body and cap
- Full bore
- Pressure rating 1000 PSI (PN63)
- Working temperature -25°C + 180°C
- Material CF8M, CF8, CF3M, WCB

#### DIMENSION LIST

SIZE	d	L	D1	D2	H	W	N • m	Kgs
1/4"	11	43	13	18.1	51	105	4	0.34
3/8"	12.5	43	13	18.1	51	105	4	0.35
1/2"	15	54	17	21.7	53	118	5	0.39
3/4"	20	73	22	27.2	60	118	8	0.71
1"	25	79	28	34	75	150	10	1.14
1 1/4"	32	90	35	42.7	80	150	14	1.58
1 1/2"	40	102	43	48.6	88	182	18	2.44
2"	50	118	54	60.5	95	182	25	3.10
2-1/2"	65	152	70	76	121	254	48	6.30
3"	80	180	85	93	135	254	75	10.65
4"	100	216.5	105	116	158	285	110	18.80

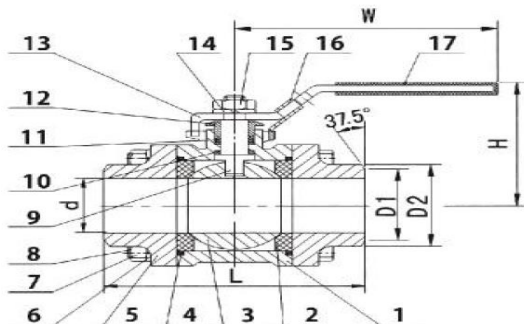

**Kspm Global Consulting Inc.**

Head Office:

1113 Kestell Blvd., Oakville, Ontario L6H 7M6 Canada.

Website: [www.kspmglobal.ca](http://www.kspmglobal.ca)

E-mail: [Operations@kspmglobal.ca](mailto:Operations@kspmglobal.ca)